

DA42-VI fact sheet



DA42-VI fact sheet

Power plant

Engines	2x Austro Engine AE 300 turbocharged common-rail injected 2.0 liter diesel engine with 168 HP and EECU single lever control system
Propellers	MT propeller MTV-6-R-C/CF 190-69 3-blade constant speed propeller
Fuel grades	Jet A-1, Jet A, TS-1 (Russia, Ukraine), RT (Russia, Ukraine), Diesel EN 590 No. 3 Jet Fuel (China), JP-8

Performance/ consumption (MTOW)

Max. cruise speed (16,000 ft, MCP), 1760 kg TOW	365 km/h TAS	197 kts TAS
Max. cruise speed (16,000 ft, MCP)	353 km/h TAS	193 kts TAS
Cruise speed at 60% (16,000 ft)	322 km/h TAS	174 kts TAS
Stall speed, clean	124 km/h CAS	67 kts CAS
Stall speed, landing configuration	113 km/h CAS	61 kts CAS
Rate of climb (ISA SL), 1760 kg TOW	9.1 m/s	1,800 fpm
Rate of climb (ISA SL)	7.1 m/s	1,400 fpm
Rate of climb (18,000 ft)	5.0 m/s	1,000 fpm
Single Engine Service Ceiling	5,486 m	18,000 ft
Range at 60%, standard-/ long range tank	1,470 km/ 2,245 km	795 nm/ 1,215 nm
Consumption at 60%	39.4 lt/hr	10.4 US gal/hr
Take-off distance 50 ft (ISA SL)	598 m	1,961 ft
Take-off ground roll (ISA SL), 1760 kg TOW	280 m	919 ft
Take-off ground roll (ISA SL)	354 m	1,161 ft
Landing distance 50 ft (ISA SL)	570 m	1,870 ft
Landing ground roll (ISA SL)	340 m	1,115 ft
Max. operating altitude	5,486 m	18,000 ft
Max. demonstrated crosswind	46 km/h	25 kts

Dimensions/ mass/ loading

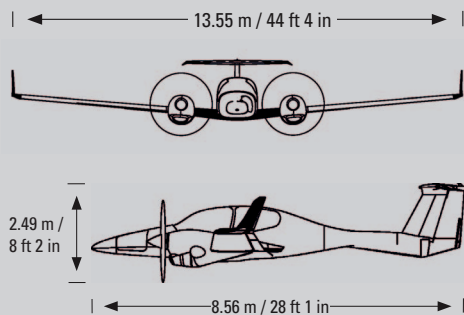

Length	8.56 m	28 ft 1 in
Height	2.49 m	8 ft 2 in
Wing span	13.55 m	44 ft 4 in
Seats	4	4
Empty weight *)	1,410 kg	3,109 lbs
MTOM	1,900 kg	4,189 lbs
Payload *)	490 kg	1,080 lbs
Fuel capacity standard-/ long range tank	189 lt/ 289 lt	50 US gal/ 76.4 US gal

*) Specifications apply to standard equipped aircraft (with DME, TAS, WX500, AUX, TKS, standard light weight interior without adjustable seats), if not otherwise stated. The above data are approximately specifications and may change without notice.

Diamond Aircraft Industries GmbH | N. A. Otto-Straße 5 | A-2700 Wiener Neustadt, Austria
T +43 2622 26700 | F +43 2622 26700-1199 | www.diamond-air.at

Version: April 16th, 2012 S_30649E © 2012 Diamond Aircraft Industries GmbH